

Damp-proof Scale

SWII-W



Damp-proof Scale SWII-W

SWII-W is damp-proof scale to ensure the stable and long use of scale in damp environment such as food processing applications and fish market. Also, it is easy to carry and its stabilization time of less than 0.6s makes fast and accurate operation.



Features

1. Suitable for damp environment

Water-resistant design of SWII-W ensures the stable and long use of the scale in damp environment such as food processing applications and fish market by channeling fluids that may enter the housing to suitably located drain hole. Also, the cased PCB and the silicone sealed connection, water-proof power connector(optional) can protect the scale from water.



2. Fast operation and High accuracy

Stabilization time of less than 0.6s and display resolution of 1/3,000 dual interval make extremely fast operation and improve efficiency

3. Large bright display

6 digits LED/LCD display offers high visibility in any lighting condition. Also, dual display design(Optional) increases productivity as two operators can work at the same time.

▶ LCD display (Character height : 35 mm, with Backlight)



▶ LED display (Character height : 20 mm)



Rear display (Optional)

4. Convenient to carry

Light-weight and portable design of SWII-W allow easy carrying of the scale with either one or two hands.



5. Stainless steel tray

6. Auto power and standby mode for economic usage

Specifications

Model	SWII-CW(LCD)				SWII-EW(LED)			
	1.5/3	3/6	6/15	15/30	1.5/3	3/6	6/15	15/30
Capacity (kg)	1.5/3	3/6	6/15	15/30	1.5/3	3/6	6/15	15/30
Readability (g)	0.5/1	1/2	2/5	5/10	0.5/1	1/2	2/5	5/10
Resolution	1/3,000(Dual Interval)							
Display	6 digit LCD (Height : 35 mm, with Backlight)				6 digit LED (Height : 20 mm)			
Key	4ea (Power, Zero, Tare, Hold)							
Function	Hold, Counting, Weighing comparison (HI/OK/LOW) Auto power off, Standby mode							
Power	Dry battery (D size 1.5V x 4ea) 9VDC/1A Adaptor (Optional)				6V 3.3A Rechargeable battery(Pb) 9VDC/1A Adaptor			
Battery Operating Time (for Single display)	Manganese dry battery : Approx. 400hours Alkaline dry battery : Approx. 800hours				Rechargeable battery : Approx. 80hours			
Operation Temperature (°C)	-10 ~ 40							
Ingress Protection	Pass the test lab which equal to IP68							
Platter Size (mm)	237 (W) x 192 (D) (SUS)							
Product Size (mm)	256 (W) x 299 (D) x 117 (H)							
Product Weight (kg)	Approx. 2.6							
Options	[For All] Rear display, Large tray (Only for capacities of 15 & 30kg), Water-proof power connector [For SWII-CW(LCD)] Adaptor 9VDC/1A							

Dimensions

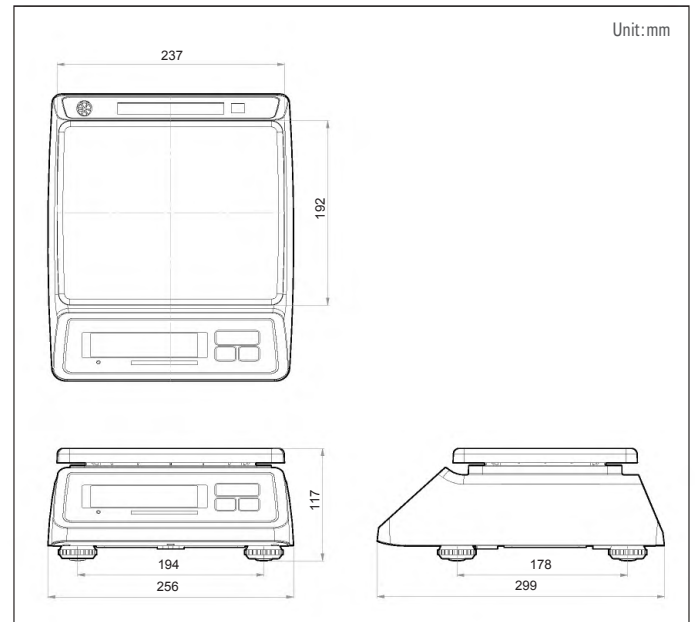

Options

- Rear display
- Water-proof power connector
- Large tray - 355(W) x 258(D) mm (Only for capacities of 15 & 30kg)
- Adaptor [only for SWII-CW(LCD type)]

